

Cerraduras de pomo

TESA

ASSA ABLOY



Especialistas y líderes en cerraduras de pomo



Más de 60 años fabricando cerraduras de pomo hacen que [TESA](#) sea un referente imprescindible en el mercado para el tipo de cerradura más extendido a nivel mundial: la cerradura de pomo, un producto fiable y muy cómodo de instalar, con infinitas posibilidades.

Facilidad y sencillez en la instalación

Las cerraduras de pomo **TESA** son un producto muy sencillo de instalar. En 3 pasos podemos equipar una puerta y tenerla en perfecto funcionamiento.

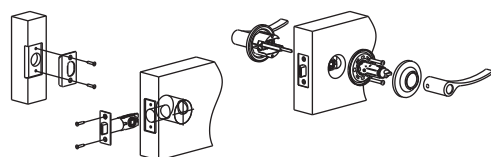

Amplia gama de funciones y acabados

TESA principal fabricante europeo de cerraduras de pomo puede ofrecerle la más amplia gama de acabados y funciones que se requieran para cada caso. Puertas de paso libre, puertas que requieren privacidad, las que se desean controlar con llave, tiradores y un largo etc. siempre acordes a los requerimientos de acabados, han demostrado cumplir con creces las exigencias y necesidades del mercado. Acabados latonados, cromados, niquelados, negros, blancos ... cuidadosamente elaborados para que resistan años.

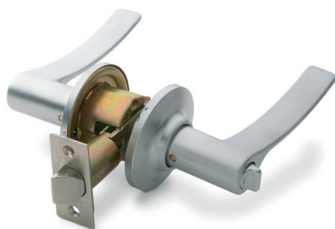

Amaestramientos y cilindros de seguridad

¿Quiere control, comodidad y seguridad en una cerradura de pomo? No tenga duda en optar por amaestrarlos con nuestros cilindros de seguridad de llave plana. Un amaestramiento le permitirá con un número muy reducido de llaves (incluso sólo con una, si es necesario) y de forma muy cómoda, abrir más de una puerta, limitar el acceso de ciertas personas a determinadas puertas y contar con la seguridad que usted necesita.



Reposición

La gran ventaja de las cerraduras de pomo es la posibilidad que nos ofrecen de cambiar y modernizar la estética de una puerta, el acabado o la función instalada en la misma, sin necesidad de tener que volver a mecanizar la puerta, sencillamente soltando una cerradura y colocando la que deseemos.



Productos certificado

Además de un producto sencillo y fácil de instalar, las cerraduras de pomo **TESA** son productos de gran resistencia, con una fijación pasante y muy duradera. Así lo avalan los cumplimientos de normas **ANSI** y **UL** que corroboran su nivel de resistencia y su durabilidad incluso en situaciones de fuego.



Garantías TESA

Comprar **TESA** es garantía de calidad. Las cerraduras de pomo **TESA** son productos de confianza total, cuya fabricación y diseño están avalados con las máximas garantías de calidad, respeto y cuidado del medioambiente que acreditan las certificaciones **ISO9001** e **ISO14001**, así como el de Seguridad en el Trabajo y Prevención de Riesgos Laborales.



Indice acabados



Latón pulido
LP

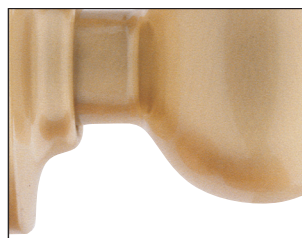

Latón mate
LM

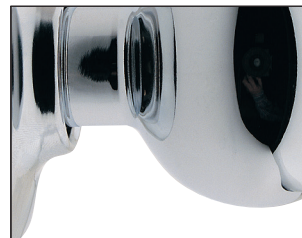

Cromo brillo
CR

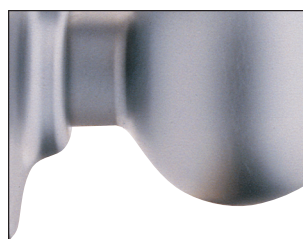

Cromo mate
CM

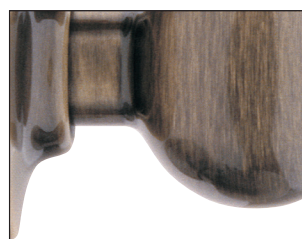

Latón antiguo
LA



Níquel satinado
NS



Marengo brillo
MB



Blanco
BL



Negro
NE

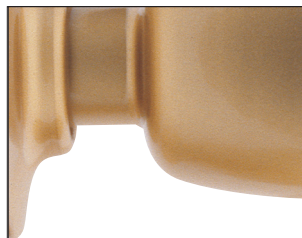

Acero esmaltado
AE

Indice visual



Sistema cuadradillo
Página 6



Cerrojos
Página 15



Escudos embellecedores
Página 16



Picaportes y cerraderos
Página 17



Colección ACCESS
Página 18

E

Sistemas cuadradillo

Ventajas al cuadrado



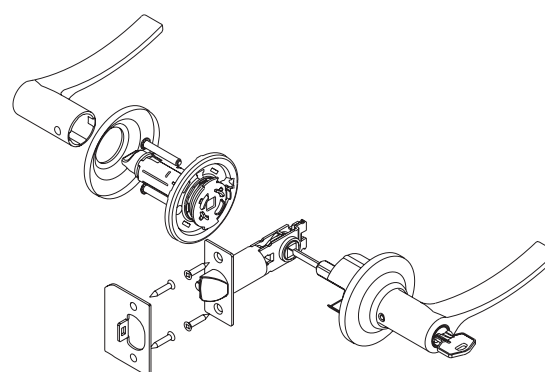
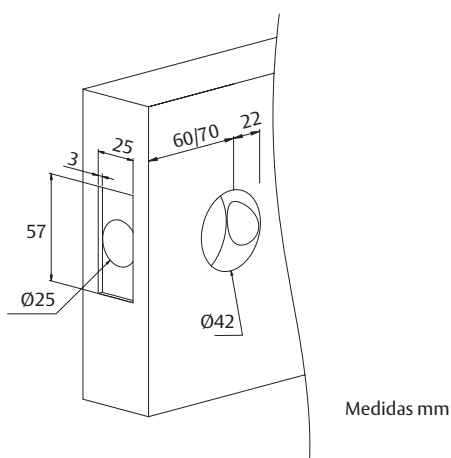



- » Mecanismo multifuncional que sirve tanto para pomo como para manilla, de gran robustez de componentes y accionamiento muy suave.
- » Es aplicable a edificios institucionales de alto tráfico de personas y edificios residenciales de tráfico medio.

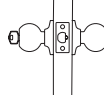
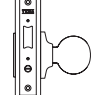
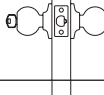

Características	Estandar	Especial
Características técnicas	Picaporte con dispositivo de seguridad antitarjeta en funciones 0, 1 y 2	Función antipánico: en puertas condenadas con llave, el interior siempre es de accionamiento libre
Resistencia anti-corrosión s/ASTM B 117/90	CR,CM,NS144 horas LP,LM 96 horas	
Espesor puerta	33-45 mm manillas 33-52 mm pomos	Hasta 75 mm
ANSI A156.2	Salvo función 07: 40-50mm Grado 2: 400.000 ciclos	
UL		Hasta 1,5 horas de exposición al fuego
Cilindro	5 pitones activos y 3 llaves	Cilindro de seguridad: T60, T80, TX80, T10, T12 Llaves iguales y amaestramientos
Picaporte	Entrada 60 ó 70 mm - unificado Saliente 12,5 mm	127 mm Frente redondeado
Accesorios	Cerradero, tornillos, instrucciones y plantilla de montaje	Cerradero redondeado
Uds. embalaje	20	

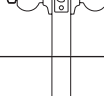
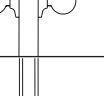
Sistemas cuadradillo

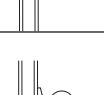
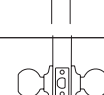
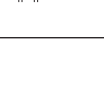
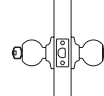
Funciones

Función	Descripción	Función	Descripción
	00 ENTRADA: ambos lados son condenados y descondenados por la llave exterior o la muletilla interior.		20 ENTRADA: condena y descondena por la llave exterior y el pomo interior. Picaporte-palanca. Aplicable a portero automático.
	01 ENTRADA: condena y descondena sólo por la llave exterior. El interior queda condenado.		31 TIRADOR FIJO: fijación pasante desde el interior.
	01AP ENTRADA: condena y descondena sólo por la llave exterior. Desde el interior siempre se puede abrir.		32 DOBLE TIRADOR FIJO
	02 AULAS: el exterior fijo, sólo se abre con llave. El interior siempre se puede abrir.		33 ENTRADA: ambos lados siempre libres, aplicable a cerraduras de embutir. No incluye cerradura.
	03 BAÑOS Y DORMITORIOS: ambos lados son condenados y descondenados por la muletilla interior. Posibilidad de descondena exterior mediante dispositivo de emergencia.		34 ENTRADA: siempre libre, aplicable a cerraduras de embutir. No incluye cerradura.
	05 PUERTAS DE PASO: ambos lados siempre libres.		
	07 OFICINAS: la llave condena y descondena cada lado de forma independiente. La condena no se transmite de un lado a otro de la puerta. Espesor de puerta: 40-50mm		

E

Intepretación del código

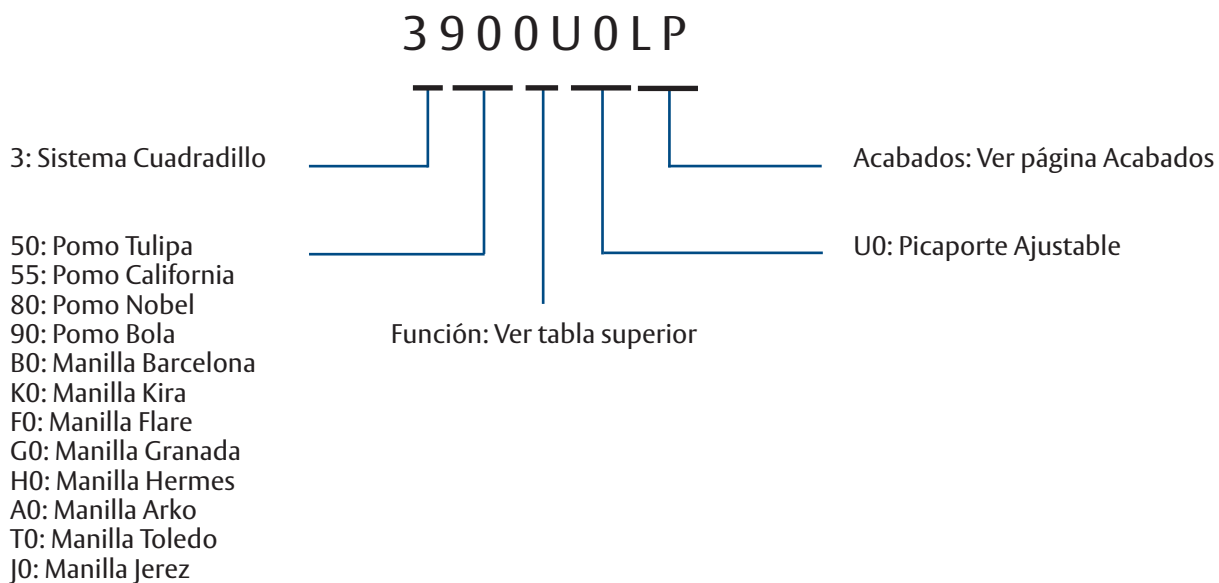

Sistema cuadradillo

Modelos de manillas

Modelo	A	B	C	Modelo	A	B	C
Barcelona	65	62	109	Flare	65	62	107
Hermes	65	62	109	Toledo	65	62	121
Kira	65	62	102	Granada	65	62	119
Arko	65	62	112	Jerez	65	62	115

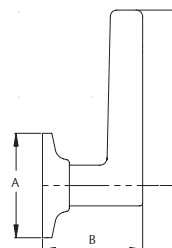

Serie Flare 3F00



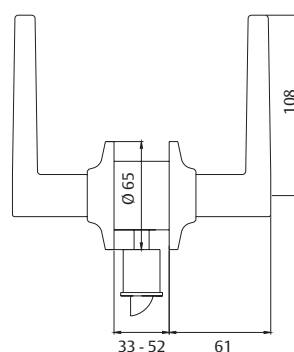





Entrada	Función	Entrada	Acabado	Embalaje
	3F00	U0	CM - CR - LM - LP - NS LA - BL - NE	20
Aula	Función	Entrada	Acabado	Embalaje
	3F02D	U0	CM - CR - LM - LP - NS LA - BL - NE	20
Aula	Función	Entrada	Acabado	Embalaje
	3F02I	U0	CM - CR - LM - LP - NS LA - BL - NE	20
Baño	Función	Entrada	Acabado	Embalaje
	3F03	U0	CM - CR - LM - LP - NS LA - BL - NE	20
Paso	Función	Entrada	Acabado	Embalaje
	3F05	U0	CM - CR - LM - LP - NS LA - BL - NE	20
Oficina	Función	Entrada	Acabado	Embalaje
	3F07	U0	CM - CR - LM - LP - NS LA - BL - NE	20
Pomo - cuadradillo	Función	Entrada	Acabado	Embalaje
	3F34D	00	CM - CR - LM - LP - NS LA - BL - NE	20
Pomo - cuadradillo	Función	Entrada	Acabado	Embalaje
	3F34I	00	CM - CR - LM - LP - NS LA - BL - NE	20



Flare





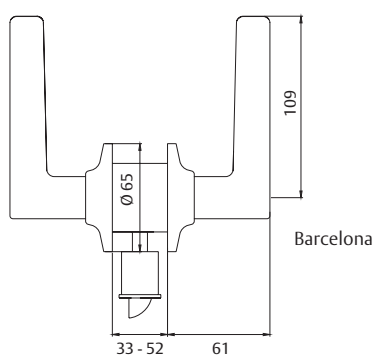

Sistema cuadradillo

Serie Barcelona 3B00

Entrada	Función	Entrada	Acabado	Embalaje
	3B00	U0	CM - CR - LM - LP - NS LA - BL - NE	20
Aula	Función	Entrada	Acabado	Embalaje
	3B02D	U0	CM - CR - LM - LP - NS LA - BL - NE	20
Aula	Función	Entrada	Acabado	Embalaje
	3B02I	U0	CM - CR - LM - LP - NS LA - BL - NE	20
Baño	Función	Entrada	Acabado	Embalaje
	3B03	U0	CM - CR - LM - LP - NS LA - BL - NE	20
Paso	Función	Entrada	Acabado	Embalaje
	3B05	U0	CM - CR - LM - LP - NS LA - BL - NE	20
Oficina	Función	Entrada	Acabado	Embalaje
	3T07	U0	CM - CR - LM - LP - NS LA - BL - NE	20
Pomo - cuadradillo	Función	Entrada	Acabado	Embalaje
	3B34D	00	CM - CR - LM - LP - NS LA - BL - NE	20
Pomo - cuadradillo	Función	Entrada	Acabado	Embalaje
	3B34I	00	CM - CR - LM - LP - NS LA - BL - NE	20



Serie Arko 3A00



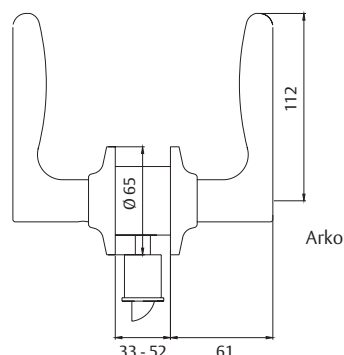





Entrada	Función	Entrada	Acabado	Embalaje
	3A00	U0	CM - CR - LM - LP - NS LA - BL - NE	20
Aula	Función	Entrada	Acabado	Embalaje
	3A02D	U0	CM - CR - LM - LP - NS LA - BL - NE	20
Aula	Función	Entrada	Acabado	Embalaje
	3A02I	U0	CM - CR - LM - LP - NS LA - BL - NE	20
Baño	Función	Entrada	Acabado	Embalaje
	3A03	U0	CM - CR - LM - LP - NS LA - BL - NE	20
PAso	Función	Entrada	Acabado	Embalaje
	3A05	U0	CM - CR - LM - LP - NS LA - BL - NE	20
Oficina	Función	Entrada	Acabado	Embalaje
	3A07	U0	CM - CR - LM - LP - NS LA - BL - NE	20
Pomo - cuadradillo	Función	Entrada	Acabado	Embalaje
	3A34D	00	CM - CR - LM - LP - NS LA - BL - NE	20
Pomo - cuadradillo	Función	Entrada	Acabado	Embalaje
	3A34I	00	CM - CR - LM - LP - NS LA - BL - NE	20



E





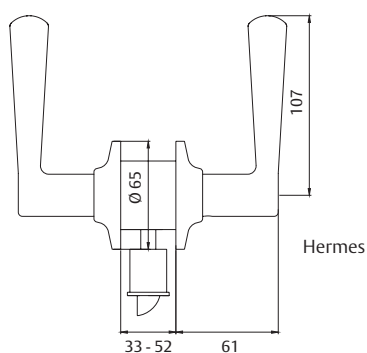

Sistema cuadradillo

Serie Hermes 3H00

Entrada	Función	Entrada	Acabado	Embalaje
	3H00	U0	CM - CR - LM - LP - NS LA - BL - NE	20
Aula	Función	Entrada	Acabado	Embalaje
	3H02D	U0	CM - CR - LM - LP - NS LA - BL - NE	20
Aula	Función	Entrada	Acabado	Embalaje
	3H02I	U0	CM - CR - LM - LP - NS LA - BL - NE	20
Baño	Función	Entrada	Acabado	Embalaje
	3H03	U0	CM - CR - LM - LP - NS LA - BL - NE	20
Paso	Función	Entrada	Acabado	Embalaje
	3H05	U0	CM - CR - LM - LP - NS LA - BL - NE	20
Oficina	Función	Entrada	Acabado	Embalaje
	3H07	U0	CM - CR - LM - LP - NS LA - BL - NE	20
Pomo - cuadradillo	Función	Entrada	Acabado	Embalaje
	3H34D	00	CM - CR - LM - LP - NS LA - BL - NE	20
Pomo - cuadradillo	Función	Entrada	Acabado	Embalaje
	3H34I	00	CM - CR - LM - LP - NS LA - BL - NE	20







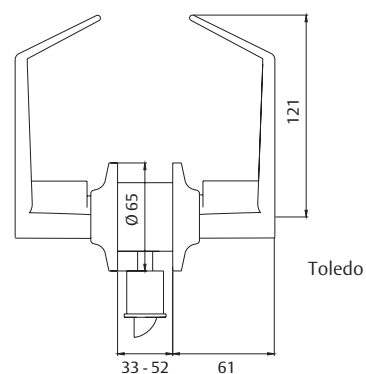

Serie Toledo 3T00

Entrada	Función	Entrada	Acabado	Embalaje
	3T00	U0	CM - CR - LM - LP - NS LA - BL - NE	20
Aula	Función	Entrada	Acabado	Embalaje
	3T02	U0	CM - CR - LM - LP - NS LA - BL - NE	20
Baño	Función	Entrada	Acabado	Embalaje
	3T03	U0	CM - CR - LM - LP - NS LA - BL - NE	20
Paso	Función	Entrada	Acabado	Embalaje
	3T05	U0	CM - CR - LM - LP - NS LA - BL - NE	20
Oficina	Función	Entrada	Acabado	Embalaje
	3T07	U0	CM - CR - LM - LP - NS LA - BL - NE	20
Pomo - cuadradillo	Función	Entrada	Acabado	Embalaje
	3T34	00	CM - CR - LM - LP - NS LA - BL - NE	20







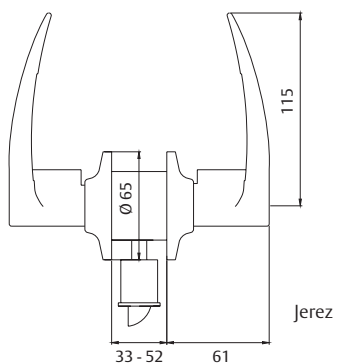

Sistema cuadradillo

Serie Jerez 3J00

Entrada	Función	Entrada	Acabado	Embalaje
	3J00	U0	CM - CR - LM - LP - NS LA - BL - NE	20
Aula	Función	Entrada	Acabado	Embalaje
	3J02	U0	CM - CR - LM - LP - NS LA - BL - NE	20
Baño	Función	Entrada	Acabado	Embalaje
	3J03	U0	CM - CR - LM - LP - NS LA - BL - NE	20
Paso	Función	Entrada	Acabado	Embalaje
	3J05	U0	CM - CR - LM - LP - NS LA - BL - NE	20
Oficina	Función	Entrada	Acabado	Embalaje
	3J07	U0	CM - CR - LM - LP - NS LA - BL - NE	20
Pomo - cuadradillo	Función	Entrada	Acabado	Embalaje
	3J34	00	CM - CR - LM - LP - NS LA - BL - NE	20



Serie Granada 3G00

Entrada	Función	Entrada	Acabado	Embalaje
	3G00	U0	CM - CR - LM - LP - NS LA - BL - NE	20
Aula	Función	Entrada	Acabado	Embalaje
	3G02	U0	CM - CR - LM - LP - NS LA - BL - NE	20
Baño	Función	Entrada	Acabado	Embalaje
	3G03	U0	CM - CR - LM - LP - NS LA - BL - NE	20
Paso	Función	Entrada	Acabado	Embalaje
	3G05	U0	CM - CR - LM - LP - NS LA - BL - NE	20
Oficina	Función	Entrada	Acabado	Embalaje
	3G07	U0	CM - CR - LM - LP - NS LA - BL - NE	20
Pomo - cuadradillo	Función	Entrada	Acabado	Embalaje
	3G34	00	CM - CR - LM - LP - NS LA - BL - NE	20

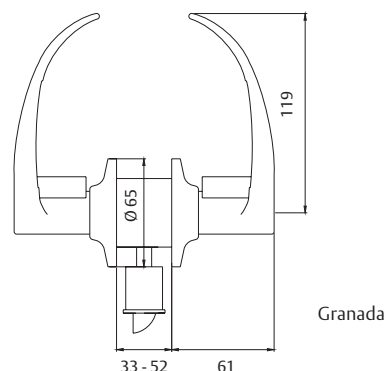





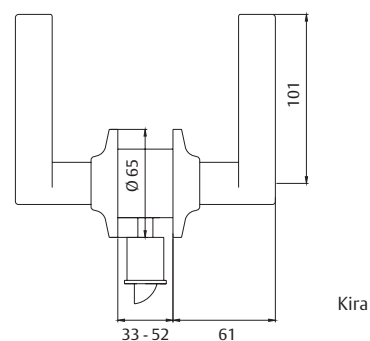

Serie Kira 3K00





Baño	Función	Entrada	Acabado	Embalaje
	3K03	U0	CM - CR - LM - LP - NS LA - BL - NE	20
Paso	Función	Entrada	Acabado	Embalaje
	3K05	U0	CM - CR - LM - LP - NS LA - BL - NE	20

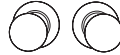

Sistema cuadradillo

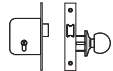
Serie Bola 3900

Entrada	Modelo	Entrada	Acabado	Embalaje
	3900	U0 UV	CM - CR - LM - LP - NS LA - BL - NE - AE	20
Puertas a condonar	Modelo	Entrada	Acabado	Embalaje
	3901	U0	CM - CR - LM - LP - NS LA - BL - NE - AE	20
Aula	Modelo	Entrada	Acabado	Embalaje
	3901AP	U0	CCM - CR - LM - LP - NS LA - BL - NE - AE	20
Aula	Modelo	Entrada	Acabado	Embalaje
	3902	U0	CM - CR - LM - LP - NS LA - BL - NE - AE	20
Baño	Modelo	Entrada	Acabado	Embalaje
	3903	U0 UV	CM - CR - LM - LP - NS LA - BL - NE - AE	20
Paso	Modelo	Entrada	Acabado	Embalaje
	3905	U0 UV	CM - CR - LM - LP - NS LA - BL - NE - AE	20
Oficina	Modelo	Entrada	Acabado	Embalaje
	3907	U0	CM - CR - LM - LP - NS LA - BL - NE - AE	20





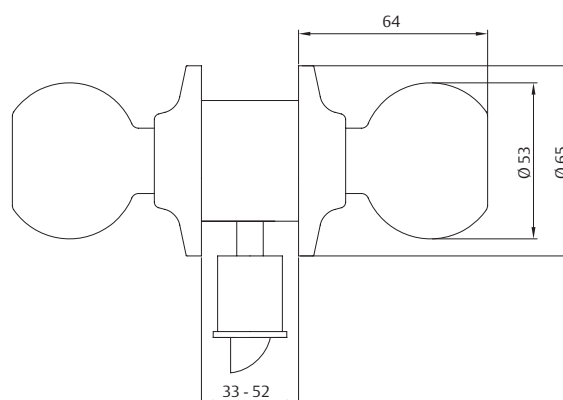

Entrada	Modelo	Entrada	Acabado	Embalaje
	3920	50	CM - CR - LM - LP - NS LA - BL - NE - AE	20
Pomo tirador	Modelo	Entrada	Acabado	Embalaje
	3931	00	CM - CR - LM - LP - NS LA - BL - NE - AE	20
Doble tirador	Modelo	Entrada	Acabado	Embalaje
	3932	00	CM - CR - LM - LP - NS LA - BL - NE - AE	20
Doble cuadradillo	Modelo	Entrada	Acabado	Embalaje
	3933	00	CM - CR - LM - LP - NS LA - BL - NE - AE	20
Pomo - cuadradillo	Modelo	Entrada	Acabado	Embalaje
	3934	00	CM - CR - LM - LP - NS LA - BL - NE - AE	20

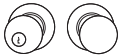

Bola

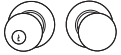

Sistema cuadradillo

Serie Tulipa 3500

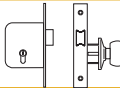
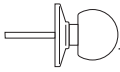
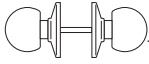
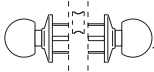
Entrada	Modelo	Entrada	Acabado	Embalaje
	3500	U0 UV	CM - CR - LM - LP - NS LA - BL - NE - AE	20
Puertas a condonar	Modelo	Entrada	Acabado	Embalaje
	3501	U0	CM - CR - LM - LP - NS LA - BL - NE - AE	20
Aula	Modelo	Entrada	Acabado	Embalaje
	3501AP	U0	CM - CR - LM - LP - NS LA - BL - NE - AE	20
Aula	Modelo	Entrada	Acabado	Embalaje
	3502	U0	CM - CR - LM - LP - NS LA - BL - NE - AE	20
Baño	Modelo	Entrada	Acabado	Embalaje
	3503	U0 UV	CM - CR - LM - LP - NS LA - BL - NE - AE	20
Paso	Modelo	Entrada	Acabado	Embalaje
	3505	U0 UV	CM - CR - LM - LP - NS LA - BL - NE - AE	20
Oficina	Modelo	Entrada	Acabado	Embalaje
	3507	U0	CM - CR - LM - LP - NS LA - BL - NE - AE	20

Entrada	Modelo	Entrada	Acabado	Embalaje
	3520	U0	CM - CR - LM - LP - NS LA - BL - NE - AE	20
Pomo tirador	Modelo	Entrada	Acabado	Embalaje
	3531	U0	CM - CR - LM - LP - NS LA - BL - NE - AE	20
Doble tirador	Modelo	Entrada	Acabado	Embalaje
	3532	U0	CM - CR - LM - LP - NS LA - BL - NE - AE	20
Doble cuadradillo	Modelo	Entrada	Acabado	Embalaje
	3533	U0	CM - CR - LM - LP - NS LA - BL - NE - AE	20
Pomo - cuadradillo	Modelo	Entrada	Acabado	Embalaje
	3534	U0	CM - CR - LM - LP - NS LA - BL - NE - AE	20



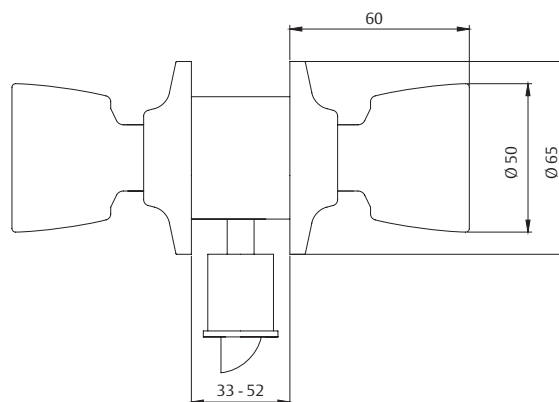

E

Tulipa







Sistema cuadradillo

Serie Nobel 3800

Entrada	Modelo	Entrada	Acabado	Embalaje
	3800	U0	CM - CR - LM - LP - NS LA	20
Hotel - Entrada	Modelo	Entrada	Acabado	Embalaje
	3802	U0	CM - CR - LM - LP - NS LA	20
Baños	Modelo	Entrada	Acabado	Embalaje
	3803	U0	CM - CR - LM - LP - NS LA	20
Paso	Modelo	Entrada	Acabado	Embalaje
	3805	U0	CM - CR - LM - LP - NS LA	20

Serie California 3550

Entrada	Modelo	Entrada	Acabado	Embalaje
	3550	U0	CM - CR - LM - LP - NS LA	20
Hotel - Entrada	Modelo	Entrada	Acabado	Embalaje
	3552	U0	CM - CR - LM - LP - NS LA	20
Baños	Modelo	Entrada	Acabado	Embalaje
	3553	U0	CM - CR - LM - LP - NS LA	20
Paso	Modelo	Entrada	Acabado	Embalaje
	3555	U0	CM - CR - LM - LP - NS LA	20

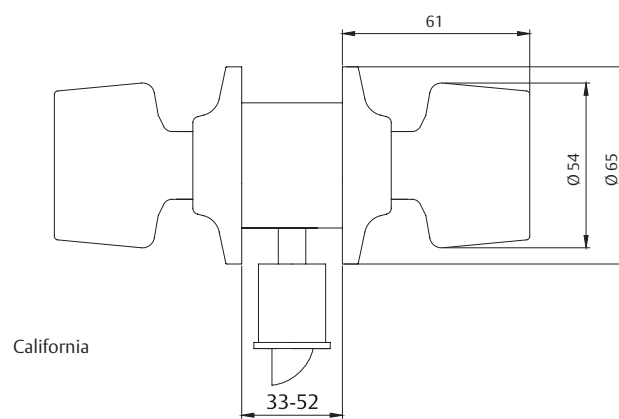
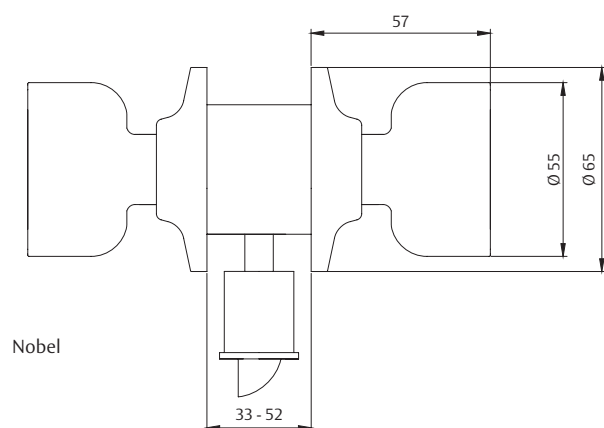

Cerrojos

Cerrojo 514

- » Cerraduras auxiliares para complemento de cerraduras de pomo.
- » Aplicable a edificios institucionales y residenciales.
- » Cerrojo con accionamiento único ADA desde el interior, que facilita su apertura. Fijación interior no pasante.

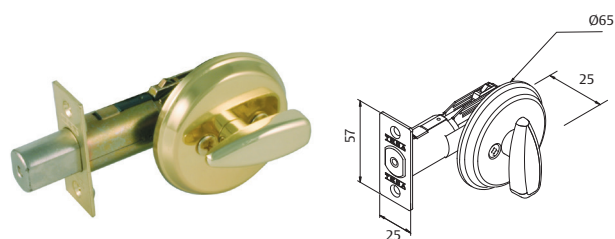

Modelo	Entrada	Acabado	Embalaje
514	60 / 70	CM - CR - LM - LP - NS - LA	20

Cerrojo 516

- » Cerraduras auxiliares para complemento de cerraduras de pomo.
- » Aplicable a edificios institucionales y residenciales.
- » Cerrojo con llave exterior y muletilla ADA interior, que facilita su apertura.

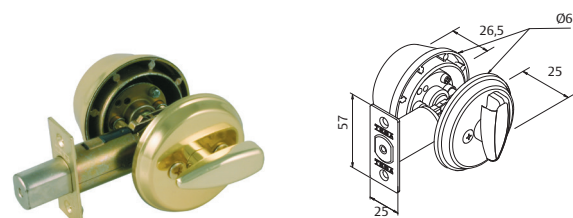

Modelo	Entrada	Acabado	Embalaje
516	60 / 70	CM - CR - LM - LP - NS - LA	20

Cerrojo 517



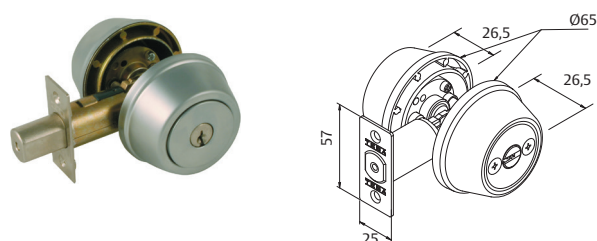



- » Cerrojo con llave en el exterior y el interior.

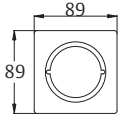

Modelo	Entrada	Acabado	Embalaje
517	60 / 70	CM - CR - LM - LP - LA - NS	20

Características	Estandar	Especial
Resistencia anti-corrosión s/ASTM B 117/90	CR,CM144 horas LP,LM.....96 horas	
Espesor puerta	33-47 mm en 514 33-52 mm en 516, 517	Hasta 72 mm en 514 Hasta 70 mm en 516
ANSI A156.2	Grado 3: 100.000 ciclos	
UL	ANSI A156.5	Hasta 1,5 horas de exposición al fuego
Muletilla	ADA que facilita el accionamiento	
Cilindro	5 pitones activos y 3 llaves	Cilindro de seguridad: T60, T80, TX80 Llaves iguales y amasetramientos
Picaporte	Entrada 60 ó 70 mm. Con dispositivo antisierra	
Accesorios	Cerradero, tornillos, instrucciones y plantilla de montaje	Cerradero redondeado
Uds. embalaje	20	

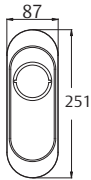
Escudos embellecedores

Modelo 461 / 45		Acabado	Embalaje	Modelo 452 / 90		Acabado	Embalaje
		CM - CR - LM - LP NS - LN	10			CM - LM - LP	10
Modelo 469 / ED		Acabado	Embalaje	Modelo 453 / 26		Acabado	Embalaje
		CM - LM - LP	10			CM - LM - LP	10

Picaportes y cerraderos

Picaporte cuadradillo

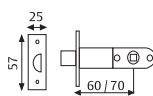
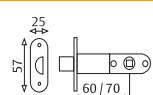
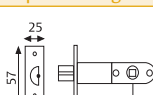
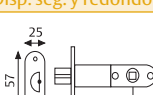
Estándar	Modelo	Acabado	Medida	Embalaje
	P030 / U0	LP - CR	60 mm	200
	P030 / 20	LP - CR	127 mm	100
Redondo 1/2	Modelo	Acabado	Medida	Embalaje
	P030 / U2	LP - CR	60 mm	200
Dispositivo seguridad	Modelo	Acabado	Medida	Embalaje
	P031 / U0	LP - CR	60 mm	200
	P031 / 20	LP - CR	127 mm	100
Disp. seg. y redondo 1/2	Modelo	Acabado	Medida	Embalaje
	P031 / U2	LP - CR	60 mm	200

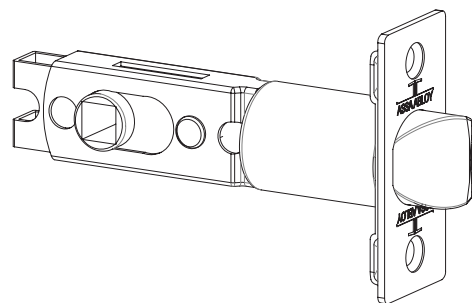

E

Cerrojo 516 y 517

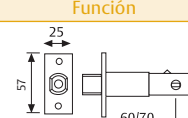
Función	Modelo	Acabado	Entrada	Embalaje
	P016	LP - CR	60 / 70	200

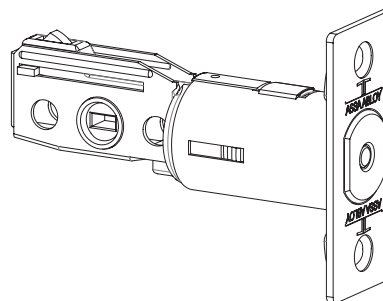

Cerraderos

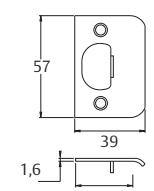
Estándar con solapa	Modelo	Acabado	Aplicación	Embalaje
	C2500	HL	Estándar	800
	C2500	HN	Estándar	800

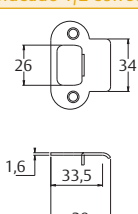
Redondeado 1/2 con solapa	Modelo	Acabado	Aplicación	Embalaje
	CR25 / 34	HL	Estándar	1000
	CR25 / 34	HN	Estándar	1000

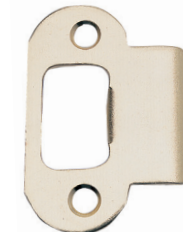

Colección Access



E

Las formas de acceso cambian. Se transforman. Evolucionan. Por ello, **TESA** lanza su nueva Colección Access. Una serie con un diseño de vanguardia destinada a revolucionar el mundo de los accesos gracias a sus diferentes modelos. Absolutamente exclusivos, originales, diferentes. Un medio de acceso tradicional que ofrece nuevas y espectaculares aplicaciones.

Colección Access: normativa

Clasificación ANSI A 156.2:1996 y UNE - EN 12209: 2003

El American National Standard Institute (ANSI), para facilitar la diferenciación en seguridad, resistencia y funcionamiento, establece tres grados para las cerraduras de puerta. Estos grados (grado 1, 2 y 3, siendo el 1 el más alto) permiten al usuario elegir el producto que más se adecua a sus necesidades de funcionamiento y seguridad.



La norma europea UNE-EN 12209 especifica los requisitos y métodos de ensayo relativos a la durabilidad, resistencia, seguridad y funcionamiento de cerraduras y picaportes accionados mecánicamente para su utilización en puertas.



Para que una cerradura sea certificado con una u otra norma, debe superar unas rigurosas pruebas, que medirán:

- » El funcionamiento: fuerzas máximas necesarias para retirar el picaporte con el pomo, con la llave, para cerrar la puerta; proyección mínima del picaporte, ...
- » La resistencia: a la torsión con el pomo condensado; a esfuerzos horizontales y verticales sobre el pomo; resistencia del picaporte mientras se golpea la puerta, ...

- » El material con el que está fabricado: resistencia del material a deformaciones por golpes, ...
- » El acabado: resistencia del acabado en ensayos de niebla salina; a los rayos UVA, a ensayos de dureza y rayado; a ensayos de sudoración.

E

Durabilidad

Llegan a superar los 400.000 ciclos o accionamientos. UNE-EN 12209: el máximo exigido por esta norma son 200.000. ANSI A 156.2: grado 2.

Par de accionamiento con el pomo condensado

Superior a 35 Nm. UNE-EN 12209: el máximo exigido por esta norma es 15Nm. ANSI A 156.2: exige 17 Nm para cumplir el grado 2.

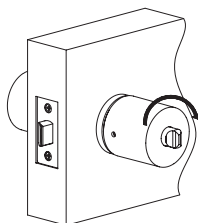

Resistencia a tiro

Superior a 150 Kg. UNE-EN 12209: el máximo exigido por esta norma para todo tipo de cerraduras. ANSI A 156.2: exige 138 Kg. para cumplir el grado 2.

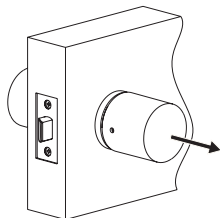

Resistencia al esfuerzo vertical y lateral

Superior a 150 Kg. UNE-EN 12209: el máximo exigido por esta norma para todo tipo de cerraduras. ANSI A 156.2: exige 115 Kg. para cumplir el grado 2.

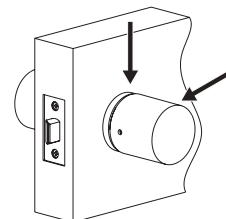

Todas las cotas están expresadas en mm.

Colección Access

Datos técnicos

Características	Estandar	Especial
Mecanismo	Altamente resistente, de apertura muy suave	
Aplicación	Edificios institucionales de alto tráfico de personas Edificios residenciales de tráfico medio	
Características técnicas	Picaporte con dispositivo de seguridad antitarjeta en funciones 0, 1 y 2	
Resistencia anticorrosión s/ASTMB117/90	CR, CM, NS: 144 horas LP, LM: 96 horas	
Espesor puerta	33 - 45 mm Salvo función 07: 40-50 mm	Hasta 60 mm con roseta 50 mm Hasta 75 mm con escudo 65 mm
Escudo	50 mm de diámetro 65 mm de diámetro	
ANSI A156.2	Grado2: 400.000 ciclos	
UL		Certificable hasta 1,5 horas de exposición al fuego
Cilindro	5 pitones activos y 3 llaves	Cilindro de seguridad: T60, T80, TX80, T10, T12 Llaves iguales
Picaporte	Entrada 60 ó 70 mm - unificado Saliente 12,5 mm	127 mm Frente redondeado
Accesorios	Cerradero, tornillos, instrucciones y plantilla de montaje	Cerradero redondeado
Uds. embalaje	20	

Modelos

Modelo	A	B	C
Coma	50 / 65	60	50
Luna	50 / 65	60	50
Mira	50 / 65	60	50
Neva	50 / 65	60	50

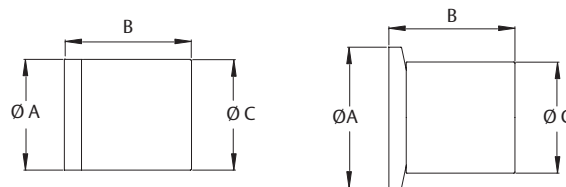

Colección Access

Funciones

	Función	Descripción		Función	Descripción
	00	ENTRADA: ambos lados son condenados y descondenados por la llave exterior o la muletilla interior.		31	TIRADOR FIJO: fijación pasante desde el interior.
	01	PUERTAS DE PASO A CONDENAR: condensa y descondensa sólo por la llave exterior. El interior queda condenado.		32	DOBLE TIRADOR FIJO.
	02	ENTRADA: el exterior fijo, sólo se abre con llave. El interior siempre se puede abrir.		33	ENTRADA: ambos lados siempre libres, aplicable a cerraduras de embutir.
	03	BAÑOS Y DORMITORIOS: ambos lados son condenados y descondenados por la muletilla (modelos con escudo de 65mm) o el pulsador (modelos con roseta de 50mm) interior. Posibilidad de descondena exterior mediante dispositivo de emergencia.		34	ENTRADA: siempre libre, aplicable a cerraduras de embutir.
	05	PUERTAS DE PASO: ambos lados siempre libres.			
	07	OFICINAS: La llave condensa y descondensa cada lado de forma independiente. No se transmite de un lado a otro de la puerta. Espesor de puerta: 40-50 mm.			

E

Acabados

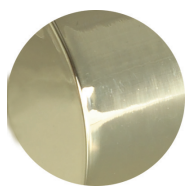

LP - Latón Pulido



LM - Latón Mate



CM - Cromo Mate

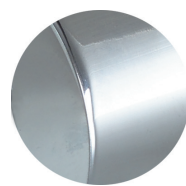

CR - Cromo Brillo

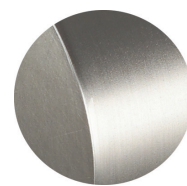

NS - Níquel Satinado

Puertas de madera y metálicas

Se adaptan a cualquier tipo de puerta, con diferentes opciones. Con dos sencillos mecanizados en el frente y en la hoja de la puerta, y un montaje rápido, puertas de madera y metálicas quedan perfectamente equipadas. Incluso en el caso de puertas previamente mecanizadas, desmontar la cerradura anterior y montar la nueva será suficiente para conseguir renovar la imagen de nuestras puertas.



Coma 



Luna 

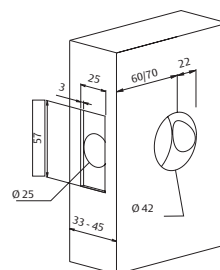

Mira 



Neva 

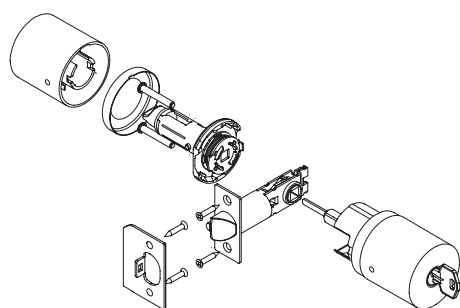
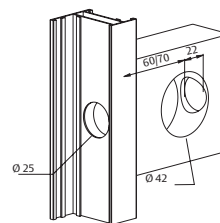

Roseta 50mm

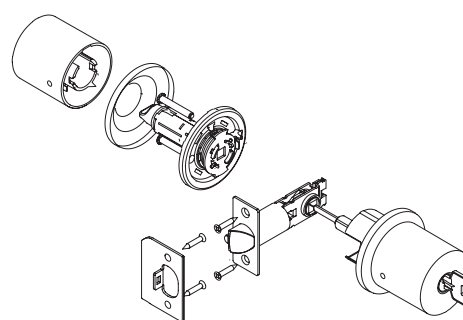

Escudo 65mm para reposición

Puertas de madera y metálicas: roseta 50 mm

Coma

Función entrada	Modelo	Mano	Entrada	Acabado	Embalaje
	3C00R	-	U0	LP	20
	3C00R	-	U0	LM	20
	3C00R	-	U0	CM	20
	3C00R	-	U0	CR	20
	3C00R	-	U0	NS	20

Puertas a condenar	Modelo	Mano	Entrada	Acabado	Embalaje
	3C01R	D/I	U0	LP	20
	3C01R	D/I	U0	LM	20
	3C01R	D/I	U0	CM	20
	3C01R	D/I	U0	CR	20
	3C01R	D/I	U0	NS	20

Hotel entrada	Modelo	Mano	Entrada	Acabado	Embalaje
	3C02R	D/I	U0	LP	20
	3C02R	D/I	U0	LM	20
	3C02R	D/I	U0	CM	20
	3C02R	D/I	U0	CR	20
	3C02R	D/I	U0	NS	20

Baños / Dormitorio	Modelo	Mano	Entrada	Acabado	Embalaje
	3C03R	-	U0	LP	20
	3C03R	-	U0	LM	20
	3C03R	-	U0	CM	20
	3C03R	-	U0	CR	20
	3C03R	-	U0	NS	20

Paso	Modelo	Mano	Entrada	Acabado	Embalaje
	3C05R	-	U0	LP	20
	3C05R	-	U0	LM	20
	3C05R	-	U0	CM	20
	3C05R	-	U0	CR	20
	3C05R	-	U0	NS	20

Oficinas	Modelo	Mano	Entrada	Acabado	Embalaje
	3C07R	-	U0	LP	20
	3C07R	-	U0	LM	20
	3C07R	-	U0	CM	20
	3C07R	-	U0	CR	20
	3C07R	-	U0	NS	20

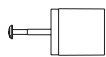
Tirador	Modelo	Mano	Entrada	Acabado	Embalaje
	3C31R	D/I	00	LP	20
	3C31R	D/I	00	LM	20
	3C31R	D/I	00	CM	20
	3C31R	D/I	00	CR	20
	3C31R	D/I	00	NS	20

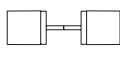
Doble tirador	Modelo	Mano	Entrada	Acabado	Embalaje
	3C32R	-	00	LP	20
	3C32R	-	00	LM	20
	3C32R	-	00	CM	20
	3C32R	-	00	CR	20
	3C32R	-	00	NS	20

Doble cuadradillo	Modelo	Mano	Entrada	Acabado	Embalaje
	3C33R	-	00	LP	20
	3C33R	-	00	LM	20
	3C33R	-	00	CM	20
	3C33R	-	00	CR	20
	3C33R	-	00	NS	20

Cuadradillo	Modelo	Mano	Entrada	Acabado	Embalaje
	3C34R	D/I	00	LP	20
	3C34R	D/I	00	LM	20
	3C34R	D/I	00	CM	20
	3C34R	D/I	00	CR	20
	3C34R	D/I	00	NS	20



E

Puertas de madera y metálicas: roseta 50 mm

Luna 

Función entrada	Modelo	Mano	Entrada	Acabado	Embalaje
	3L00R	-	U0	LP	20
	3L00R	-	U0	LM	20
	3L00R	-	U0	CM	20
	3L00R	-	U0	CR	20
	3L00R	-	U0	NS	20

Puertas a condenar	Modelo	Mano	Entrada	Acabado	Embalaje
	3L01R	D/I	U0	LP	20
	3L01R	D/I	U0	LM	20
	3L01R	D/I	U0	CM	20
	3L01R	D/I	U0	CR	20
	3L01R	D/I	U0	NS	20

Hotel entrada	Modelo	Mano	Entrada	Acabado	Embalaje
	3L02R	D/I	U0	LP	20
	3L02R	D/I	U0	LM	20
	3L02R	D/I	U0	CM	20
	3L02R	D/I	U0	CR	20
	3L02R	D/I	U0	NS	20

Baños / Dormitorio	Modelo	Mano	Entrada	Acabado	Embalaje
	3L03R	-	U0	LP	20
	3L03R	-	U0	LM	20
	3L03R	-	U0	CM	20
	3L03R	-	U0	CR	20
	3L03R	-	U0	NS	20

Paso	Modelo	Mano	Entrada	Acabado	Embalaje
	3L05R	-	U0	LP	20
	3L05R	-	U0	LM	20
	3L05R	-	U0	CM	20
	3L05R	-	U0	CR	20
	3L05R	-	U0	NS	20

Oficinas	Modelo	Mano	Entrada	Acabado	Embalaje
	3L07R	-	U0	LP	20
	3L07R	-	U0	LM	20
	3L07R	-	U0	CM	20
	3L07R	-	U0	CR	20
	3L07R	-	U0	NS	20

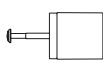
Tirador	Modelo	Mano	Entrada	Acabado	Embalaje
	3L31R	D/I	00	LP	20
	3L31R	D/I	00	LM	20
	3L31R	D/I	00	CM	20
	3L31R	D/I	00	CR	20
	3L31R	D/I	00	NS	20

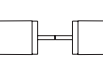
Doble tirador	Modelo	Mano	Entrada	Acabado	Embalaje
	3L32R	-	00	LP	20
	3L32R	-	00	LM	20
	3L32R	-	00	CM	20
	3L32R	-	00	CR	20
	3L32R	-	00	NS	20





Doble cuadradillo	Modelo	Mano	Entrada	Acabado	Embalaje
	3L33R	-	00	LP	20
	3L33R	-	00	LM	20
	3L33R	-	00	CM	20
	3L33R	-	00	CR	20
	3L33R	-	00	NS	20





Cuadradillo	Modelo	Mano	Entrada	Acabado	Embalaje
	3L34R	D/I	00	LP	20
	3L34R	D/I	00	LM	20
	3L34R	D/I	00	CM	20
	3L34R	D/I	00	CR	20
	3L34R	D/I	00	NS	20



Puertas de madera y metálicas: roseta 50 mm

Neva

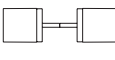
Función entrada	Modelo	Mano	Entrada	Acabado	Embalaje
	3N00R	-	U0	LP	20
	3N00R	-	U0	LM	20
	3N00R	-	U0	CM	20
	3N00R	-	U0	CR	20
	3N00R	-	U0	NS	20
Puertas a condonar	Modelo	Mano	Entrada	Acabado	Embalaje
	3N01R	-	U0	LP	20
	3N01R	-	U0	LM	20
	3N01R	-	U0	CM	20
	3N01R	-	U0	CR	20
	3N01R	-	U0	NS	20
Hotel entrada	Modelo	Mano	Entrada	Acabado	Embalaje
	3N02R	-	U0	LP	20
	3N02R	-	U0	LM	20
	3N02R	-	U0	CM	20
	3N02R	-	U0	CR	20
	3N02R	-	U0	NS	20
Baños / Dormitorio	Modelo	Mano	Entrada	Acabado	Embalaje
	3N03R	-	U0	LP	20
	3N03R	-	U0	LM	20
	3N03R	-	U0	CM	20
	3N03R	-	U0	CR	20
	3N03R	-	U0	NS	20
Paso	Modelo	Mano	Entrada	Acabado	Embalaje
	3N05R	-	U0	LP	20
	3N05R	-	U0	LM	20
	3N05R	-	U0	CM	20
	3N05R	-	U0	CR	20
	3N05R	-	U0	NS	20





Oficinas	Modelo	Mano	Entrada	Acabado	Embalaje
	3N07R	-	U0	LP	20
	3N07R	-	U0	LM	20
	3N07R	-	U0	CM	20
	3N07R	-	U0	CR	20
	3N07R	-	U0	NS	20
Tirador	Modelo	Mano	Entrada	Acabado	Embalaje
	3N31R	-	00	LP	20
	3N31R	-	00	LM	20
	3N31R	-	00	CM	20
	3N31R	-	00	CR	20
	3N31R	-	00	NS	20
Doble tirador	Modelo	Mano	Entrada	Acabado	Embalaje
	3N32R	-	00	LP	20
	3N32R	-	00	LM	20
	3N32R	-	00	CM	20
	3N32R	-	00	CR	20
	3N32R	-	00	NS	20
Doble cuadradillo	Modelo	Mano	Entrada	Acabado	Embalaje
	3N33R	-	00	LP	20
	3N33R	-	00	LM	20
	3N33R	-	00	CM	20
	3N33R	-	00	CR	20
	3N33R	-	00	NS	20
Cuadradillo	Modelo	Mano	Entrada	Acabado	Embalaje
	3N34R	-	00	LP	20
	3N34R	-	00	LM	20
	3N34R	-	00	CM	20
	3N34R	-	00	CR	20
	3N34R	-	00	NS	20



E



Puertas de madera y metálicas: roseta 50 mm

Mira

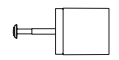
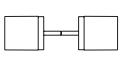
Función entrada	Modelo	Mano	Entrada	Acabado	Embalaje
	3M00R	-	U0	LP	20
	3M00R	-	U0	LM	20
	3M00R	-	U0	CM	20
	3M00R	-	U0	CR	20
	3M00R	-	U0	NS	20
Puertas a condenar	Modelo	Mano	Entrada	Acabado	Embalaje
	3M01R	-	U0	LP	20
	3M01R	-	U0	LM	20
	3M01R	-	U0	CM	20
	3M01R	-	U0	CR	20
	3M01R	-	U0	NS	20
Hotel entrada	Modelo	Mano	Entrada	Acabado	Embalaje
	3M02R	-	U0	LP	20
	3M02R	-	U0	LM	20
	3M02R	-	U0	CM	20
	3M02R	-	U0	CR	20
	3M02R	-	U0	NS	20
Baños / Dormitorio	Modelo	Mano	Entrada	Acabado	Embalaje
	3M03R	-	U0	LP	20
	3M03R	-	U0	LM	20
	3M03R	-	U0	CM	20
	3M03R	-	U0	CR	20
	3M03R	-	U0	NS	20
Paso	Modelo	Mano	Entrada	Acabado	Embalaje
	3M05R	-	U0	LP	20
	3M05R	-	U0	LM	20
	3M05R	-	U0	CM	20
	3M05R	-	U0	CR	20
	3M05R	-	U0	NS	20

Oficinas	Modelo	Mano	Entrada	Acabado	Embalaje
	3M07R	-	U0	LP	20
	3M07R	-	U0	LM	20
	3M07R	-	U0	CM	20
	3M07R	-	U0	CR	20
	3M07R	-	U0	NS	20
Tirador	Modelo	Mano	Entrada	Acabado	Embalaje
	3M31R	-	00	LP	20
	3M31R	-	00	LM	20
	3M31R	-	00	CM	20
	3M31R	-	00	CR	20
	3M31R	-	00	NS	20
Doble tirador	Modelo	Mano	Entrada	Acabado	Embalaje
	3M32R	-	00	LP	20
	3M32R	-	00	LM	20
	3M32R	-	00	CM	20
	3M32R	-	00	CR	20
	3M32R	-	00	NS	20
Doble cuadradillo	Modelo	Mano	Entrada	Acabado	Embalaje
	3M33R	-	00	LP	20
	3M33R	-	00	LM	20
	3M33R	-	00	CM	20
	3M33R	-	00	CR	20
	3M33R	-	00	NS	20
Cuadradillo	Modelo	Mano	Entrada	Acabado	Embalaje
	3M34R	-	00	LP	20
	3M34R	-	00	LM	20
	3M34R	-	00	CM	20
	3M34R	-	00	CR	20
	3M34R	-	00	NS	20





Puertas de madera y metálicas: escudo 65 mm

Coma

Función entrada	Modelo	Mano	Entrada	Acabado	Embalaje
	3C00	-	U0	LP	20
	3C00	-	U0	LM	20
	3C00	-	U0	CM	20
	3C00	-	U0	CR	20
	3C00	-	U0	NS	20

Puertas a condenar	Modelo	Mano	Entrada	Acabado	Embalaje
	3C01	D/I	U0	LP	20
	3C01	D/I	U0	LM	20
	3C01	D/I	U0	CM	20
	3C01	D/I	U0	CR	20
	3C01	D/I	U0	NS	20

Hotel entrada	Modelo	Mano	Entrada	Acabado	Embalaje
	3C02	D/I	U0	LP	20
	3C02	D/I	U0	LM	20
	3C02	D/I	U0	CM	20
	3C02	D/I	U0	CR	20
	3C02	D/I	U0	NS	20

Baños / Dormitorio	Modelo	Mano	Entrada	Acabado	Embalaje
	3C03	-	U0	LP	20
	3C03	-	U0	LM	20
	3C03	-	U0	CM	20
	3C03	-	U0	CR	20
	3C03	-	U0	NS	20

Paso	Modelo	Mano	Entrada	Acabado	Embalaje
	3C05	-	U0	LP	20
	3C05	-	U0	LM	20
	3C05	-	U0	CM	20
	3C05	-	U0	CR	20
	3C05	-	U0	NS	20

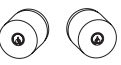
Oficinas	Modelo	Mano	Entrada	Acabado	Embalaje
	3C07	-	U0	LP	20
	3C07	-	U0	LM	20
	3C07	-	U0	CM	20
	3C07	-	U0	CR	20
	3C07	-	U0	NS	20

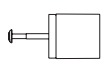
Tirador	Modelo	Mano	Entrada	Acabado	Embalaje
	3C31	D/I	00	LP	20
	3C31	D/I	00	LM	20
	3C31	D/I	00	CM	20
	3C31	D/I	00	CR	20
	3C31	D/I	00	NS	20

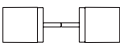
Doble tirador	Modelo	Mano	Entrada	Acabado	Embalaje
	3C32	-	00	LP	20
	3C32	-	00	LM	20
	3C32	-	00	CM	20
	3C32	-	00	CR	20
	3C32	-	00	NS	20

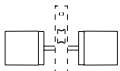
Doble cuadradillo	Modelo	Mano	Entrada	Acabado	Embalaje
	3C33	-	00	LP	20
	3C33	-	00	LM	20
	3C33	-	00	CM	20
	3C33	-	00	CR	20
	3C33	-	00	NS	20

Cuadradillo	Modelo	Mano	Entrada	Acabado	Embalaje
	3C34	D/I	00	LP	20
	3C34	D/I	00	LM	20
	3C34	D/I	00	CM	20
	3C34	D/I	00	CR	20
	3C34	D/I	00	NS	20





Puertas de madera y metálicas: escudo 65 mm

Luna

Función entrada	Modelo	Mano	Entrada	Acabado	Embalaje
	3L00	-	U0	LP	20
	3L00	-	U0	LM	20
	3L00	-	U0	CM	20
	3L00	-	U0	CR	20
	3L00	-	U0	NS	20

Puertas a condenar	Modelo	Mano	Entrada	Acabado	Embalaje
	3L01	D/I	U0	LP	20
	3L01	D/I	U0	LM	20
	3L01	D/I	U0	CM	20
	3L01	D/I	U0	CR	20
	3L01	D/I	U0	NS	20

Hotel entrada	Modelo	Mano	Entrada	Acabado	Embalaje
	3L02	D/I	U0	LP	20
	3L02	D/I	U0	LM	20
	3L02	D/I	U0	CM	20
	3L02	D/I	U0	CR	20
	3L02	D/I	U0	NS	20

Baños / Dormitorio	Modelo	Mano	Entrada	Acabado	Embalaje
	3L03	-	U0	LP	20
	3L03	-	U0	LM	20
	3L03	-	U0	CM	20
	3L03	-	U0	CR	20
	3L03	-	U0	NS	20

Paso	Modelo	Mano	Entrada	Acabado	Embalaje
	3L05	-	U0	LP	20
	3L05	-	U0	LM	20
	3L05	-	U0	CM	20
	3L05	-	U0	CR	20
	3L05	-	U0	NS	20

Oficinas	Modelo	Mano	Entrada	Acabado	Embalaje
	3L07	-	U0	LP	20
	3L07	-	U0	LM	20
	3L07	-	U0	CM	20
	3L07	-	U0	CR	20
	3L07	-	U0	NS	20

Tirador	Modelo	Mano	Entrada	Acabado	Embalaje
	3L31	D/I	00	LP	20
	3L31	D/I	00	LM	20
	3L31	D/I	00	CM	20
	3L31	D/I	00	CR	20
	3L31	D/I	00	NS	20

Doble tirador	Modelo	Mano	Entrada	Acabado	Embalaje
	3L32	-	00	LP	20
	3L32	-	00	LM	20
	3L32	-	00	CM	20
	3L32	-	00	CR	20
	3L32	-	00	NS	20





Doble cuadradillo	Modelo	Mano	Entrada	Acabado	Embalaje
	3L33	-	00	LP	20
	3L33	-	00	LM	20
	3L33R	-	00	CM	20
	3L33	-	00	CR	20
	3L33	-	00	NS	20



Cuadradillo	Modelo	Mano	Entrada	Acabado	Embalaje
	3L34	D/I	00	LP	20
	3L34	D/I	00	LM	20
	3L34	D/I	00	CM	20
	3L34	D/I	00	CR	20
	3L34	D/I	00	NS	20



Puertas de madera y metálicas: escudo 65 mm

Neva

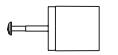
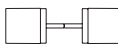
Función entrada	Modelo	Mano	Entrada	Acabado	Embalaje
	3N00	-	U0	LP	20
	3N00	-	U0	LM	20
	3N00	-	U0	CM	20
	3N00	-	U0	CR	20
	3N00	-	U0	NS	20
Puertas a condenar	Modelo	Mano	Entrada	Acabado	Embalaje
	3N01	-	U0	LP	20
	3N01	-	U0	LM	20
	3N01	-	U0	CM	20
	3N01	-	U0	CR	20
	3N01	-	U0	NS	20
Hotel entrada	Modelo	Mano	Entrada	Acabado	Embalaje
	3N02	-	U0	LP	20
	3N02	-	U0	LM	20
	3N02	-	U0	CM	20
	3N02	-	U0	CR	20
	3N02	-	U0	NS	20
Baños / Dormitorio	Modelo	Mano	Entrada	Acabado	Embalaje
	3N03	-	U0	LP	20
	3N03	-	U0	LM	20
	3N03	-	U0	CM	20
	3N03	-	U0	CR	20
	3N03	-	U0	NS	20
Paso	Modelo	Mano	Entrada	Acabado	Embalaje
	3N05	-	U0	LP	20
	3N05	-	U0	LM	20
	3N05	-	U0	CM	20
	3N05	-	U0	CR	20
	3N05	-	U0	NS	20





Oficinas	Modelo	Mano	Entrada	Acabado	Embalaje
	3N07	-	U0	LP	20
	3N07	-	U0	LM	20
	3N07	-	U0	CM	20
	3N07	-	U0	CR	20
	3N07	-	U0	NS	20
Tirador	Modelo	Mano	Entrada	Acabado	Embalaje
	3N31	-	00	LP	20
	3N31	-	00	LM	20
	3N31	-	00	CM	20
	3N31	-	00	CR	20
	3N31	-	00	NS	20
Doble tirador	Modelo	Mano	Entrada	Acabado	Embalaje
	3N32	-	00	LP	20
	3N32	-	00	LM	20
	3N32	-	00	CM	20
	3N32	-	00	CR	20
	3N32	-	00	NS	20
Doble cuadradillo	Modelo	Mano	Entrada	Acabado	Embalaje
	3N33	-	00	LP	20
	3N33	-	00	LM	20
	3N33	-	00	CM	20
	3N33	-	00	CR	20
	3N33	-	00	NS	20
Cuadradillo	Modelo	Mano	Entrada	Acabado	Embalaje
	3N34	-	00	LP	20
	3N34	-	00	LM	20
	3N34	-	00	CM	20
	3N34	-	00	CR	20
	3N34	-	00	NS	20



E

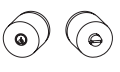

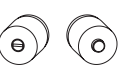
Puertas de madera y metálicas: escudo 65 mm

Mira

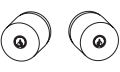
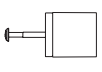
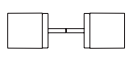
Función entrada	Modelo	Mano	Entrada	Acabado	Embalaje
	3M00	-	U0	LP	20
	3M00	-	U0	LM	20
	3M00	-	U0	CM	20
	3M00	-	U0	CR	20
	3M00	-	U0	NS	20
Puertas a condenar	Modelo	Mano	Entrada	Acabado	Embalaje
	3M01	-	U0	LP	20
	3M01	-	U0	LM	20
	3M01	-	U0	CM	20
	3M01	-	U0	CR	20
	3M01	-	U0	NS	20
Hotel entrada	Modelo	Mano	Entrada	Acabado	Embalaje
	3M02	-	U0	LP	20
	3M02	-	U0	LM	20
	3M02	-	U0	CM	20
	3M02	-	U0	CR	20
	3M02	-	U0	NS	20
Baños / Dormitorio	Modelo	Mano	Entrada	Acabado	Embalaje
	3M03	-	U0	LP	20
	3M03	-	U0	LM	20
	3M03	-	U0	CM	20
	3M03	-	U0	CR	20
	3M03	-	U0	NS	20
Paso	Modelo	Mano	Entrada	Acabado	Embalaje
	3M05	-	U0	LP	20
	3M05	-	U0	LM	20
	3M05	-	U0	CM	20
	3M05	-	U0	CR	20
	3M05	-	U0	NS	20

Oficinas	Modelo	Mano	Entrada	Acabado	Embalaje
	3M07	-	U0	LP	20
	3M07	-	U0	LM	20
	3M07	-	U0	CM	20
	3M07	-	U0	CR	20
	3M07	-	U0	NS	20
Tirador	Modelo	Mano	Entrada	Acabado	Embalaje
	3M31	-	00	LP	20
	3M31	-	00	LM	20
	3M31	-	00	CM	20
	3M31	-	00	CR	20
	3M31	-	00	NS	20
Doble tirador	Modelo	Mano	Entrada	Acabado	Embalaje
	3M32	-	00	LP	20
	3M32	-	00	LM	20
	3M32	-	00	CM	20
	3M32	-	00	CR	20
	3M32	-	00	NS	20
Doble cuadradillo	Modelo	Mano	Entrada	Acabado	Embalaje
	3M33	-	00	LP	20
	3M33	-	00	LM	20
	3M33	-	00	CM	20
	3M33	-	00	CR	20
	3M33	-	00	NS	20
Cuadradillo	Modelo	Mano	Entrada	Acabado	Embalaje
	3M34	-	00	LP	20
	3M34	-	00	LM	20
	3M34	-	00	CM	20
	3M34	-	00	CR	20
	3M34	-	00	NS	20



Notas

A series of horizontal dashed lines for writing notes.

